

V2 UNIVERSAL BRAKE INSTRUCTIONS FOR AERO 125RC, 125 SRX, 150S, & 150SC

Caution! Read all instructions before mounting and using the brake. When ordering Brakes you must specify the model of the ski.

Tools Required: Included with the Brake is a 9/64" Allen Hex key, a # 13 (4.7 mm) and a # 25 (3.8mm) drill bit. You need one 9 mm wrench, an electric screwdriver, a 10 mm socket or open wrench and a 5 mm Allen Hex Key.

LOCATION OF THE BRAKE ON THE SKI: In order to mount the brake you need at least 1.125" (29. mm) of space from the end of the ski shaft to the binding or to the back of your boot. Clean the ski where the brake is to be located with Alcohol, Fantastic or other grease removing cleaner and wipe dry. With the spring engaged and the plunger in the locked position as shown in Fig. 2, locate the assembly so that there is about 1.5 mm to 5 mm (1/16" to 3/16") of space between the brake pad and the tire. Draw a line on the ski shaft where the Bottom Support is to be located as shown in Fig. 3

MOUNTING THE BOTTOM SUPPORT TO THE SKI SHAFT: Remove the rear wheel using a 10 MM wrench and a 5 mm Allen Hex Key as shown in Fig.4. Remove the adhesive tape liner from the drill jig and place the jig on the line that you drew. (The 2 holes face front.) The sides of the drill jig line up with the grooves in the shaft. Drill the 3 holes with the small drill bit, Fig.5. Next remove the jig and enlarge the 3 holes with the large drill bit, Fig 6. Remove the socket screw in the Bottom Support using a 9 mm wrench and the 9 /64 hex key as shown in Fig. 7. Push the Nylon Shoulder Bushing out far enough so you can separate the Bottom Support from the Brake Assembly. Place the Shaft Support inside the shaft and when the holes are aligned with the Bottom Support install the Socket screws using the 9/64 Allen Hex key. (See Fig. 7A & 8) Tighten the first screw slightly, then install next two screws making sure the Bottom Support is still aligned on the ski. Tighten all screws until secure. Replace the rear wheel.

MOUNTING THE BRAKE ASSEMBLY TO THE BOTTOM SUPPORT: The Brake Assembly pivots on the nylon bushing and the **non threaded** portion of the socket screw. Place the Brake Assembly into the Bottom Support, align the holes and push the Nylon Shoulder Bushing into the Bottom Arm. Insert the socket screw, making sure the head of the screw is on the opposite side from the nylon shoulder bushing as seen in Fig. 9. Place the nut on the screw and tighten. **Do not over tighten.** Tighten just enough so the Brake Assembly moves smoothly in the Bottom Support. To lower the Brake pull the Plunger Pin and lower the assembly as in Fig. 16. To raise the Brake pull the Plunger out and lift the Brake Assembly until the Bottom Arm covers the Plunger Pin. Release the plunger and place the spring over the spring retainer as seen in Fig. 10. Fold the Brake assembly backwards until the Plunger Pin engages and locks the Brake Assembly.

ADJUSTING THE BRAKE: With your ski boots on, put the boots into the binding as if skiing. You want the padded Yoke support in a position so when skiing it does not touch your leg. You can move the Top Arm forward or backward, as shown in Fig. 12, by slightly loosening the two screws with the Allen key as shown in Fig. 11 and the upper yoke can also be moved as shown in Fig. 13. The Yoke should touch your leg **only** when you are in a braking **Telemark** position with your brake leg about .5 meter (19 In.) in front of the other ski, knee pushed all the way back. Once you have the Pivot in the approximate position **tighten the two socket screws so the upper arm does not move when you brake.** Secondary adjustments can be made by placing the upper Yoke assembly in a different location. Once you have tested the brake to make sure the position is OK drill a hole through the Top Arm using the #25 drill bit by inserting the drill bit in the hole of the Bottom Arm as shown in Fig.14. Install the safety screw as shown in Fig.15. There are safety screw holes on each side of the Bottom Arm. **Additional Adjustments:** The Spacers can be used to further adjust the Brake Pad. If you want to move the Brake Pad on the Bottom Arm, the Spacers can be used to get the Brake Pad closer to the wheel.

USING THE BRAKE: Practice braking on flat surfaces and on very gentle slopes. As you get more accustomed to using the Brake you might want to make minor adjustments with the Yoke Assembly. This is generally sufficient. If greater adjustments are required, remove the safety screw and loosen the two screws of the Center Pivot and readjust. Once you are satisfied, drill another safety hole and install the safety screw. If the new hole is too close to the old screw hole, drill the hole on the other side of the Arm. When not skiing pull the Spring Plunger and fold the Brake assembly forward over the binding as shown in Fig. 16.

MAINTENANCE: Check regularly to make sure all screws are tight and look for worn parts. Replace the Brake Pad if it's getting thin. Lubricate the pivot with a dry lubricant such as STAR X-Dry.

SAFETY: Roller skiing can be dangerous. Wear a helmet and other protective gear and use common sense when roller skiing.

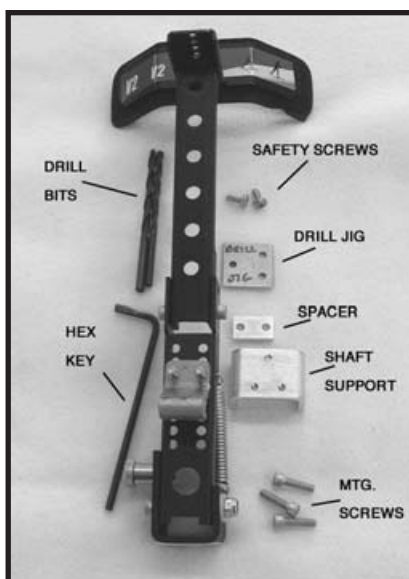

FIG.1

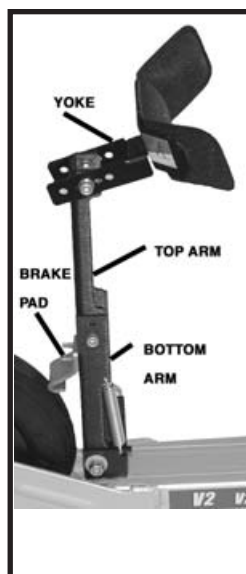

FIG. 2

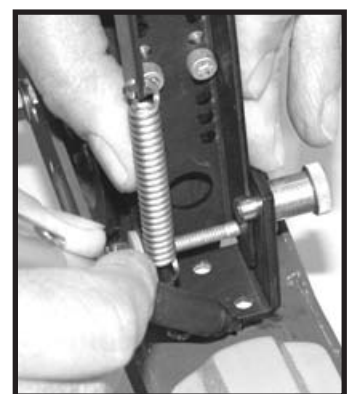

FIG.3



FIG. 4



FIG. 5



FIG. 6



FIG. 7

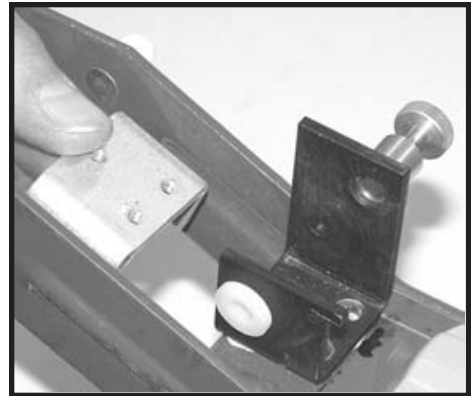

FIG. 7A

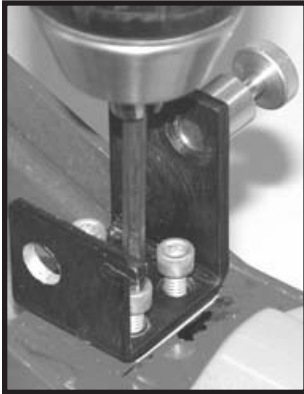

FIG. 8

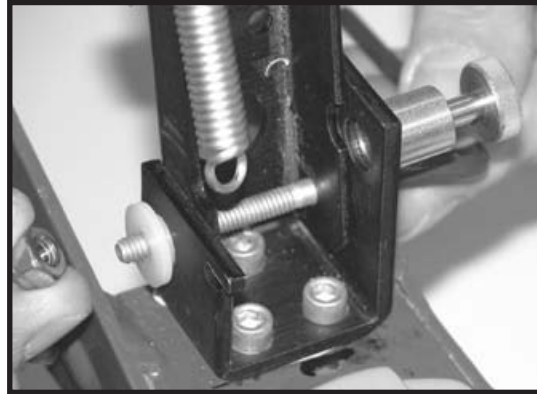

FIG. 9

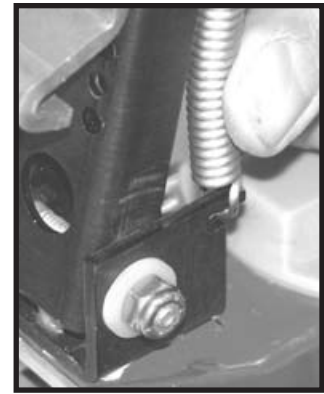

FIG. 10



FIG. 11



FIG. 12



FIG. 13



FIG. 14



FIG. 15

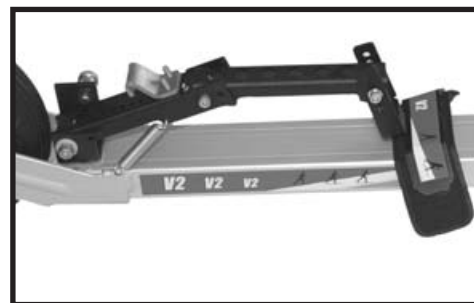

FIG. 16

V2 Jenex Inc. 172 South St. Milford, NH 03055 Tel. 603-672-2600 Fax. 603-672-5751
V2 roller skis, including brakes, are protected by several patents and patents pending.

